

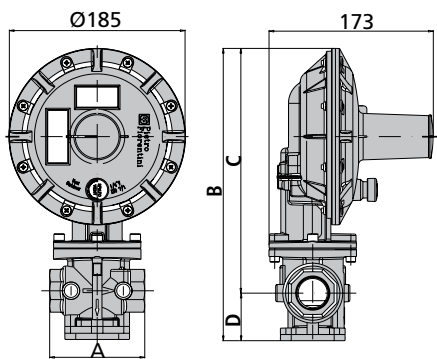

Dival 500

Reduktory Ciśnienia

WYMIARY
Dival 500

Dival 500		
	Dival 500 1"x1"	Dival 500 1"x1"1/2
A	100±1	130±1
B	299	307
C	255±1	257±1
D	44	50
DnE	1"ISO 7/1	1"ISO 7/1
DnU	1"ISO 7/1	1"1/2 ISO 7/1

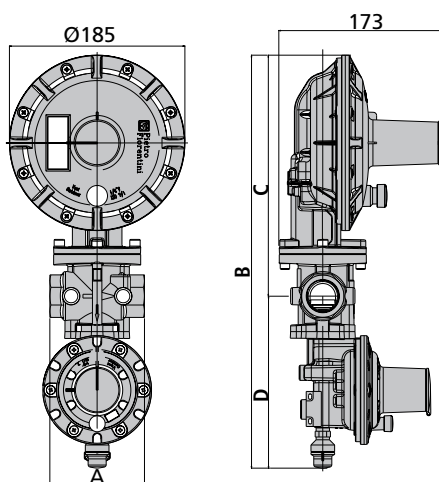

Dival 500 + LA		
	Dival 500+LA 1"x1"	Dival 500+LA 1"x1"1/2
A	100±1	130±1
B	437±2	445±2
C	255±1	257±1
D	182±±1	188±±1
DnE	1"ISO 7/1	1"ISO 7/1
DnU	1"ISO 7/1	1"1/2 ISO 7/1

Wymiary gabarytowe w mm



Stacje redukcyjne



Pomiary



Przepustnice



Powyższe dane nie są wiążące. Producent zastrzega sobie prawo do wprowadzenia ewentualnych zmian bez uprzedzenia.

CT-s 552-E październik 14